



# LRE 120

## A STABLE RUNNING UNIT THAT OFFERS A GREAT LEVEL OF FLEXIBILITY

Flexaline offers air forced cooling for high temperature stability and quick temperature recovery after door openings.



AIR FORCED COOLING



EASY ADJUSTABLE SHELVES



VARIOUS SAFETY FEATURES

### EXTRA SECURITY

The Flexaline has multiple safety features as standard. The range comes with a built-in lock to restrict access to the stored samples. Besides the physical security features, the line comes with electronic safety features. The temperature display has a high/low temperature audio and visual alarms along with a door open alarm. The controller records the minimum and maximum temperature since the last reset, and this ensures that your samples have never gone out of the set temperature range.

### FLEXIBLE STORAGE

The Flexaline offers a great level of flexibility and covering a large spectrum of different storage needs.

The shelves in the Flexaline are specially designed for easy adjustments in order to offer the best flexibility for your storage needs. This allows the user to organize their unit exactly as desired.

### PRODUCT BENEFITS

- Easily adjustable shelves to accommodate any storage need you might have
- Air-forced cooling for high-temperature stability and quick temperature recovery after door openings
- Key lock on all models for optimal security of your samples
- Interior LED light offers a good overview of your samples
- Anti-freeze thermostat

## MAIN DIMENSION FOR LRE 120

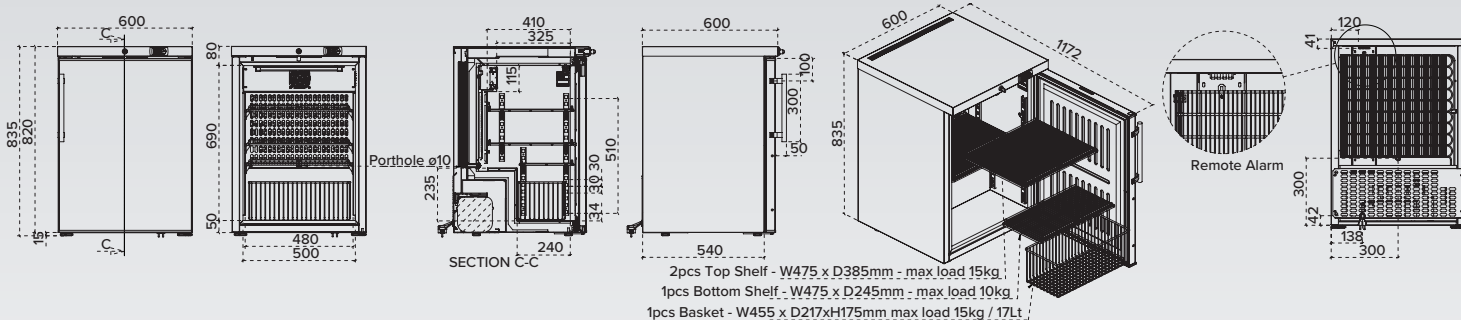

\*All measurements in mm



The Carel controller features, among others, visual and acoustic alarm, high/low temperature alarm and open door alarm.



Lock is a standard feature in our Flexaline for optimal security



The shelves in the Flexaline are easy adjustable in order to offer best flexibility for your storage needs

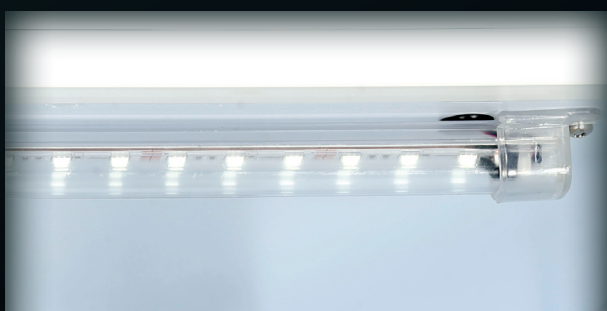

All models in our Flexaline feature LED lighting offering long time durability and lowest possible operating cost

### OPTIONAL ACCESSORIES

- SVS voltage stabilizer
- GSM alarm module
- Shelves
- Basket

### MAIN SPECIFICATIONS

Item code	DAI 6020
Temperature range (°C)	+2 / +8
Max. ambient temperature (°C)	32
Capacity (L)	117
Exterior dimensions WxDxH (mm)	600x600x835
Interior dimensions WxDxH (mm)	480x410/240x690
Weight (KG)	51
Insulation (mm)	50
Cooling technology	air forced
Controller model / probe type	Carel / NTC

### POWER

Power supply (V)	230
Frequency (Hz)	50/60
Power consumption (kWh/24H)	0,9
AMP (A)	0,5
Power (Watt)	107
Horse power (HP)	1/6

### ALARM FUNCTIONS

Alarm display as text - not codes	no
Visual / acoustic alarm	yes / yes
Power failure alarm	no
Adjustable high / low temperature alarm	yes / yes
Open door alarm	yes
Probe failure alarm	yes
Low battery alarm	no
Compressor failure alarm	no
Battery backup for alarms (approx. hrs.)	no

### DATA LOGGING & EXTERNAL CONNECTION

Voltage free contact for remote alarm (e.g. GSM alarm module)	yes
Electronic data logger	no
RS 485 port	no
USB port for software update & data download	no
Temperature chart recorder	no

### DISPLAY FEATURES

Display type	LED display with touch buttons
Number of optional reference probes	no
Password protection for turning unit on / off	no
Temperature graph on display	no

### OTHER FEATURES

Automatic defrost	yes
Antifreeze function	no
Vacuum release port	no
Access port for external probe etc. (int. diameter mm)	12
Light	yes
Lock with key	yes
Castors (total pcs) / castors with brake (pcs)	no
Fixed feet (pcs) / levelling feet (pcs)	0 / 4
Sub lids / inner doors (pcs)	no
Reversible door(s)	yes
Fixed shelves (pcs) / adjustable shelves (pcs)	0 / 2 + 1 small
Max. no. of shelves (pcs) / recommended max. no. of shelves (pcs)	4 + 1 small / 2 + 1 small
Max. load per shelf (kg)	15 / 10 (small shelf)
Baskets (pcs)	1
Max. no. of baskets (pcs)	1
Max. load per basket (kg)	15

### REFRIGERATION & CABINET

Number of compressors	1
Refrigerant	R600a
Interior cabinet material	coated steel
Exterior cabinet material	coated steel
Colour (exterior cabinet)	white
Foam type	polyurethane
VIP vacuum insulated panels	no

### SHIPPING

Shipping weight (KG)	59
Shipping dimensions WxDxH (cm)	80x65x102
Shipping volume (m <sup>3</sup> )	0,53